



Process: Quality Control
 Category: Global
 Document type: Instruction
 Language: English
 IHT: Internal

Title: AQL- Female Hygiene Kit

Document ID: TSLOG-16-86484
 Document Status: Approved
 Effective date: 12/28/2022
 GDP related: No
 Version: 9.0

Definitions:

- Critical nonconformity** : Any discrepancy which might harm a user or makes it impossible to use the product properly is considered to be critical. Lots with Critical discrepancies is subject to lot refusal.
- Major nonconformity** : Any discrepancy which makes the use of the product less efficient than expected is considered to be major. Lot with Major discrepancies can be accepted.
- Minor nonconformity** : Any discrepancy which does not have an influence on the performance of the product is considered to be minor. Lot with Minor discrepancies can be accepted.
- Nonconformity**: Non-fulfilment of a specified characteristic requirement.
- Nonconforming item**: Item with one or more nonconformities.
- Lot**: Definite amount of some product, material or service, collected together
- Sample**: Set of one or more items taken from a lot and intended to provide information on the lot

Non-Conformities and Corrective Action:

Critical: (AQL 0)

Determination of lot acceptability: to be decided by ICRC' Quality and buyers.

Continual improvement: Improvement plan to be proposed by supplier and validated by the ICRC to eliminate the root cause of occurrence and non detection for the faced non-conformity (ies) for the upcoming purchases. Actions to be implemented by supplier within a defined time frame by default 3 months.

Penalty: 10% penalty of the value of the total PO per each critical non-conformity to be charged to the supplier .

Major: (AQL 2.5)

Determination of lot acceptability: to be decided by ICRC' Quality and buyers.

Continual improvement: Improvement plan to be proposed by supplier and validated by the ICRC to eliminate the root cause of occurrence and non detection for the faced non-conformity (ies) for the upcoming purchases. Actions to be implemented by supplier within a defined time frame by default 3 months.

Penalty: 0.5% penalty of the value of the total PO per each major non-conformity to be charged to the supplier.

Minor: (AQL 4.0)

Determination of lot acceptability: to be decided by ICRC' Quality and buyers.

Continual improvement: Improvement plan to be proposed by supplier and validated by the ICRC to eliminate the root cause of occurrence and non detection for the faced non-conformity (ies) for the upcoming purchases. Actions to be implemented by supplier within a defined time frame by default 3 months.

Penalty: 0.25% penalty of the value of the total PO per each minor non-conformity to be charged to the supplier.

Additional Information:

The Method of testing is drawn from ISO-2859-1 International Standards (table1: Sample size code letters, and table 2-A: Single sampling plans for normal inspection). The samples will be taken randomly by the buyer from the delivered items and then inspected. The buyer can decide either to inspect the lot at ICRC QC laboratory or to use an inspection company for analysis, or both. Transport to laboratory and analysis cost for lab testing are at expense of ICRC. The seller can contest the results of the Quality Control done at ICRC warehouses by requesting a lab testing. In this case transport to laboratory and analysis cost for lab testing are at expense of the seller. In case the ICRC decides to hold the penalties during the improvement plan, if the faced nonconformity(ies) persist ; penalty for each non-conformity faced during the improvement plan will be applied.



Process: Quality Control
 Category: Global
 Document type: Instruction
 Language: English
 IHT: Internal

Title: AQL- Female Hygiene Kit

Document ID: TSLOG-16-86484
 Document Status: Approved
 Effective date: 12/28/2022
 GDP related: No
 Version: 9.0

Nonconformities classification: Critical: C; Major: M; Minor: m

Items	Characteristics	Nonconformities classification	QC type	AQL	QC Inspection at ICRC warehouses and lab testing
Parcel	Marking on the carton box	m	Ok/Nok	4.0	Marking expected for standard requests: One side of the box: PO number + Female hygiene Kits, 50 kits (15S, 25M, 10L) + total weight. Opposite side of the box: ICRC logo. No logo of the supplier/manufacturer allowed. Additional marking as per contract.
	Quantity of kits per box	m	Ok/Nok	4.0	Standard requests: 50 kits per box, 15 Small (S) kits (2 underwears (S) + 3 absorbent pads and 1 super absorbent pad + 1 Carrying bag); 25 Medium (M) kits (2 underwears (M) + 3 absorbent pads and 1 super absorbent pad + 1 Carrying bag); 10 Large (L) kits (2 underwears (L) + 3 absorbent pads and 1 super absorbent pad +1 Carrying bag); Non-standard requests :As per purchasing contract
	Box sealing	m	Ok/Nok	4.0	Control that the box is well sealed with long lasting 50mm tape, and secured with 2 straps.
	Box general quality	m	Ok/Nok	4.0	Export-quality 5 ply cardboard strong enough to withstand multiple handling and stacking up to 6 m . No holes, no tears.
Primary packaging	Marking on the primary packaging	m	Ok/Nok	4.0	Clearly marked: the size ("S", "M" or "L") and content "2 underwears+3 absorbent pads and 1 super absorbent pad + 1 Carrying bag". Non-standard requests :As per purchasing contract
	General quality	m	Ok/Nok	4.0	Individual kit packaging could be carton box, cloth bag or the carrying bag itself. No holes, no tears. No extra plastic bag allowed.
	Quantity per kit	M	Ok/Nok	2.5	2 underwears (of the same size)+3 absorbent pads and 1 super absorbent pad + 1 Carrying bag
Underwears	Material	C	Ok/Nok	0	100% cotton, Neat and clean fabric, one way stretch at least (in width). Certificate of material conformity to be provided for each order by supplier.
	Washing	M	Ok/Nok	2.5	Washable underwears, quality sufficient to withstand minimum 10 washes. Washing temperature: MIN 40 degrees. No deterioration or loss of elasticity of bands.
	Colours	m	Ok/Nok	4.0	Plain color dark blue, black, purple or brown
	Elastic number	M	Ok/Nok	2.5	3 elastic bands: 1 for the waistband, 1 for each thigh
	Elastic quality	M	Ok/Nok	2.5	MAX 20% shorter than measurement of fabric. Elastic type: Picot edge , Fold over or regular elastic



Process: Quality Control
 Category: Global
 Document type: Instruction
 Language: English
 IHT: Internal

Title: AQL- Female Hygiene Kit

Document ID: TSLOG-16-86484
 Document Status: Approved
 Effective date: 12/28/2022
 GDP related: No
 Version: 9.0

Nonconformities classification: Critical: **C**; Major: **M**; Minor: **m**

Underwears	Elastic waistband width	M	Measurement	2.5	Minimum width: 8 mm minimum
	Elastic thigh band width	M	Measurement	2.5	Minimum width: 8 mm minimum
	Stitching	M	Ok/Nok	2.5	Zigzag stitching well hemmed with cotton thread, Machine made, no run or broken stitches
	Finishing	m	Ok/Nok	4.0	Good quality tidy finish, no open seams, no hole and no cut. Seams must stretch along with the fabric to prevent thread breakage.
	Inside leg	M	Measurement	2.5	Inside leg made of double layers (one as crotch lining), 100 % cotton
	Waistband, flat & extended	M	Measurement	2.5	Refer to the drawing / table attached.
	Thigh, flat & extended	M	Measurement	2.5	Refer to the drawing / table attached.
	Height front	M	Measurement	2.5	Refer to the drawing / table attached.
	Height back	M	Measurement	2.5	Refer to the drawing / table attached.
	Height side	M	Measurement	2.5	Refer to the drawing / table attached.
	Crotch width	M	Measurement	2.5	Refer to the drawing / table attached.
	Crotch length	M	Measurement	2.5	Refer to the drawing / table attached.
	Weight	M	Measurement	2.5	Refer to the drawing / table attached.
	Instruction label length	m	Measurement	4.0	Minimum label length: 20 mm minimum
	Instruction label width	m	Measurement	4.0	Minimum label width: 10 mm minimum
Size (Small or Medium or Large or X Large) labels	m	Ok/Nok	4.0	Each underwear with a label well stitched, clearly indicate 100% cotton and size.	



ICRC

Process: Quality Control
 Category: Global
 Document type: Instruction
 Language: English
 IHT: Internal

Title: AQL- Female Hygiene Kit

Document ID: TSLOG-16-86484
 Document Status: Approved
 Effective date: 12/28/2022
 GDP related: No
 Version: 9.0

Nonconformities classification: Critical: C; Major: M; Minor: m

Absorbent pads	General quality	M	Ok/Nok	2.5	Soft fabric, no bad smell, no skin irritation. Appropriate for use with underwear (fold under the crotch of the underwear and closure with plastic button)
	Material	C	Ok/Nok	0	<p style="text-align: center;">Top ; Absorbent layer of Micro fleece 100 % Polyester or 100% cotton (towel type) Inside; The absorbance part (see attached pictures) consists of at least two additional layers of 100% cotton (towel type) or 2 absorbent layers of Micro fleece,80% polyester and 20% polyamide Bottom; Waterproof layer of Polyurethane Laminate (PUL) Certificate of material conformity to be provided for each order by supplier.</p>
	Shape	M	Ok/Nok	2.5	Winged, refer to the pictures attached.
	Washing	M	Ok/Nok	2.5	Washable pads, quality sufficient to withstand minimum 10 washes. Washing temperature: MIN 40 degrees.
	Stitching	M	Ok/Nok	2.5	Firmly stitched with overlock, using soft non-irritating thread. The absorbent part centered on the pad is also firmly stitched using soft non-irritating thread (see photos).
	Colours	m	Ok/Nok	4.0	Plain color: Blue, black, purple,Pink or brown. Color well fixed on the pad (the pad being immersed in clear water, the water should not be colored in the color of the pad).
	Absorption	M	Measurement	2.5	The pad must have an absorption capacity of at least 40 ml (put the pad into a container filled with water for 5 minutes. Remove the pad when the trickle of water that flows from the pad becomes drops , measure the amount of water absorbed).
	Length	M	Measurement	2.5	Refer to the pictures attached. Tolerance: +/- 5%
	Width	M	Measurement	2.5	Refer to the pictures attached. Tolerance: +/- 5%
	Thickness	M	Measurement	2.5	MIN 4.5 mm. at the middle of the pad.
Button	M	Ok/Nok	2.5	Plastic snap button, diameter min 12mm. Metal snap buttons not accepted.	



Process: Quality Control
 Category: Global
 Document type: Instruction
 Language: English
 IHT: Internal

Title: AQL- Female Hygiene Kit

Document ID: TSLOG-16-86484
 Document Status: Approved
 Effective date: 12/28/2022
 GDP related: No
 Version: 9.0

Nonconformities classification: Critical: C; Major: M; Minor: m

Super absorbent pads	General quality	M	Ok/Nok	2.5	Soft fabric, no bad smell, no skin irritation. Appropriate for use with underwear (fold under the crotch of the underwear and closure with plastic button).
	Material	C	Ok/Nok	0	<p>Top ; Absorbent layer of Micro fleece 100 % Polyester or 100% cotton (towel type)</p> <p>Inside; The absorbance part (see attached pictures) consists of at least two additional layers of 100% cotton (towel type) or 2 absorbent layers of Micro fleece,80% polyester and 20% polyamide</p> <p>Bottom; Waterproof layer of Polyurethane Laminate (PUL)</p> <p>Certificate of material conformity to be provided for each order by supplier.</p>
	Shape	M	Ok/Nok	2.5	Winged, refer to the pictures attached.
	Washing	M	Ok/Nok	2.5	Washable pads, quality sufficient to withstand minimum 10 washes. Washing temperature: MIN 40 degrees.
	Stitching	M	Ok/Nok	2.5	Firmly stitched with overlock, using soft non-irritating thread. The absorbent part centered on the pad is also firmly stitched using soft non-irritating thread (see photos).
	Colours	m	Ok/Nok	4.0	Plain color: Blue, black, purple,Pink or brown. Color well fixed on the pad (the pad being immersed in clear water, the water should not be colored in the color of the pad).
	Absorption	M	Measurement	2.5	The pad must have an absorption capacity of at least 60 ml (put the pad into a container filled with water for 5 minutes. Remove the pad when the trickle of water that flows from the pad becomes drops , measure the amount of water absorbed).
	Length	M	Measurement	2.5	Refer to the pictures attached. Tolerance: +/- 5%
	Width	M	Measurement	2.5	Refer to the pictures attached. Tolerance: +/- 5%
	Thickness	M	Measurement	2.5	MIN 4.5 mm. at the middle of the pad.
Button	M	Ok/Nok	2.5	Plastic snap button, diameter min 12mm. Metal snap buttons not accepted.	
Carrying bag	Material	C	Ok/Nok	0	Soft, waterproof (plastic or PUL)
	Shape	M	Ok/Nok	2.5	Envelope-style storage bag. Refer to the pictures attached.
	Length	M	Measurement	2.5	Mini 150 mm,
	Width	M	Measurement	2.5	Mini 120 mm
	General quality	M	Ok/Nok	2.5	No holes, no tears.



Process: Quality Control
 Category: Global
 Document type: Instruction
 Language: English
 IHT: Internal

Title: AQL- Female Hygiene Kit

Document ID: TSLOG-16-86484
 Document Status: Approved
 Effective date: 12/28/2022
 GDP related: No
 Version: 9.0

Size: US&UK / Dimensions EU (mm),

Parameters / Parameters	S / 38 Small	M / 40 Medium	L / 42 Large	For info XL / 44 Extra Large
A Waistband, flat(at rest) tolerance: +/-5%	250	270	300	320
A Waistband, stretched tolerance: +/-10%	430	450	470	500
B Thigh, flat(at rest) tolerance: +/-5%	190	210	230	240
B Thigh, stretched tolerance: +/-10%	290	310	330	360
C Height front tolerance: +/-5%	190	200	210	240
D Height back tolerance: +/-5%	200	210	220	250
E Height side tolerance: +/- 10%	75	75	75	75
F Crotch width tolerance: +/-5%	80	80	80	80
G Crotch length tolerance: +/-5%	130	130	130	130
H underwear weight in g tolerance: +/-10%	35	40	45	50

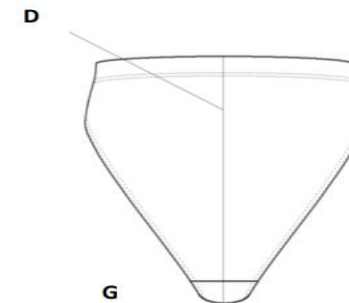
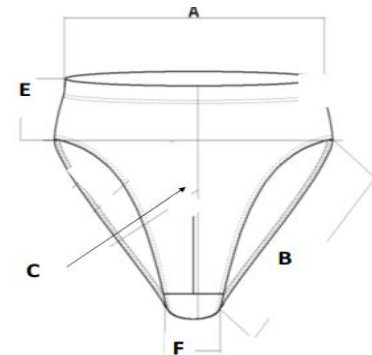

Measurement A- waistband, flat



Measurement A- waistband, stretched



Measurement B- Thigh, Flat



Measurement B- Thigh, Stretched



Measurement C- Height Front



Measurement D- Height Back



Measurement E- Height Side



Measurement F



Measurement G- Bottom Length



ICRC

Process: Quality Control
Category: Global
Document type: Instruction
Language: English
IHT: Internal

Title: AQL- Female Hygiene Kit

Document ID: TSLOG-16-86484
Document Status: Approved
Effective date: 12/28/2022
GDP related: No
Version: 9.0

- Carrying bag



- Plastic snap button on both wings (to fold under the inside leg underwear)



- Absorbent pads

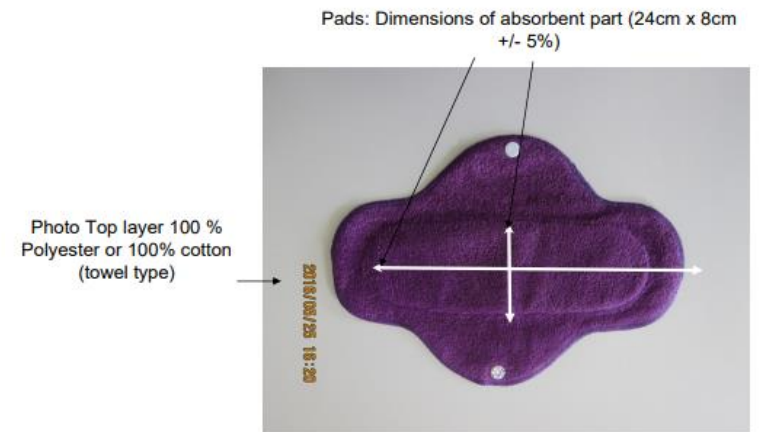
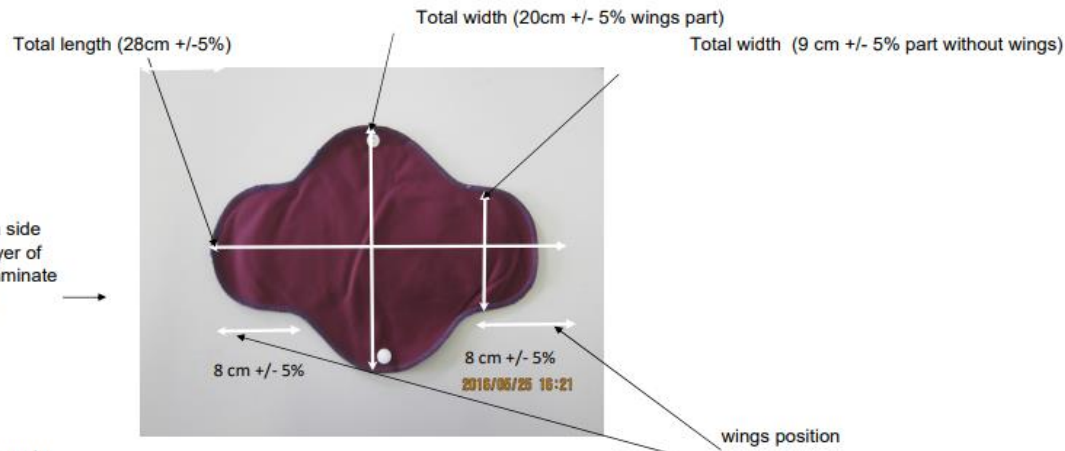

- Super absorbent pads

